

Mercedes-Benz GLE 450 AMG Coupé

Make the best of every ground.



AMG
DRIVING PERFORMANCE



In every family there's someone who breaks out.

Experience the best from the world of cars in a new, sensational form: the contemporary luxury of a Mercedes-Benz. The presence of an SUV. The dynamism and agility of a coupé. Characteristically Mercedes, excitingly different. The GLE Coupé. Make the best of every ground.

Pioneering on any terrain.

- | | |
|--|---|
| 18 Engine: AMG enhanced biturbo V6 | 36 Multimedia and Navigation System |
| 19 9G-TRONIC automatic transmission | 38 Assistance Systems |
| 20 DYNAMIC SELECT | 39 Safety |
| 22 AIRMATIC With ADS Plus | 40 Genuine Accessories |
| 23 AMG-specific 4MATIC all-wheel drive | 44 Upholstery, Trim and Alloy |
| 24 Technical Highlights | 45 Paintwork |
| 27 Exterior Highlights | 46 Technical Data |
| 28 LED Intelligent Light System | 47 Dimensions |
| 29 Mirror Package | 48 Service |
| 31 Interior Highlights | 50 India's Largest Luxury Car Network |
| 32 Standard Equipment | |



Unadapted.
And extremely adaptable.

*Please read the disclaimer.

What the design promises is surpassed by the engineering – with a unique symbiosis of sportiness, comfort and individuality. Via the DYNAMIC SELECT Controller you can choose from up to five transmission modes: “Comfort”, “Sport”, “Sport Plus”, “Slippery” and “Individual”. They produce a driving experience totally in accordance with your wishes. Thanks to the AIRMATIC air suspension and Adaptive Damping System ADS PLUS, the damping is automatically adjusted on a permanent basis.



The new Mercedes-Benz GLE 450 AMG Coupé

Now there is even more output, even more adrenalin, even more AMG in the Mercedes-Benz portfolio. Sharpened drive systems, brake and exhaust systems plus special chassis components that are pure AMG, facilitate re-entry to the high-performance class. The "Sport Plus" drive mode is standard: with a higher moving-off engine speed, later shift points, tauter damping and additional lowering of the vehicle. A sports light function with a more dynamic active light function and a faster Highbeam Assist is also active. The new Mercedes-Benz GLE 450 AMG Coupé. The beginning of a great passion.

The image shows the front interior of a Mercedes-Benz GLE Coupé. The view is from the driver's perspective, looking towards the passenger side. The dashboard is dark with a large, centrally-mounted infotainment screen displaying a music playlist titled 'Mercedes-Benz Mixed Tape #55'. Below the screen are physical buttons and a rotary knob for climate control. The steering wheel is black with perforated leather and features the Mercedes-Benz logo and 'AIRBAG' text. The instrument cluster behind the steering wheel shows a speedometer, tachometer, and a digital display with the time '10:10', speed '123.0 km/h', and odometer '26593'. The center console has a gear selector and handbrake. The seats are black leather with a ribbed pattern on the side panels. The background shows a scenic view of a valley and mountains through the windshield and side windows.

No room for modesty.

Revel in more style and modernity. The 20.3 cm media display sits enthroned in the cockpit, elegantly glazed and with thrilling resolution. The progressive highlight of the GLE Coupé is the comprehensive digital networking with Mercedes-Benz Apps and ultramodern navigation system.

Understatement is overrated.

In the art of automotive engineering the Mercedes-Benz GLE 450 AMG Coupé stands for a new expressionism. Sensational proportions, broad shoulders and powerfully modelled wheel arches lend the design its sensual purity. The coupé-like silhouette, the wide track and, light-alloy wheels sized 53.3 cm (21 inches) embody power and dynamism. For a completely new, confident radiance.



Its design idiom:



The talk of the town.

Inconspicuous. Resting in itself. That, too, is the new Mercedes-Benz GLE 450 AMG Coupé. It is already equipped with the new automatic transmission 9G-TRONIC. An innovation you will barely notice – so smooth are the gear changes, so low the revs. This quiet and serenity: the result of maximum effortless superiority.

An expression of strength. And splendour.

The vertical three-dimensionally modelled sports grille is the defining characteristic at the front. The bonnet is highly contoured with powerdomes, perfectly framed by delicately styled LED High Performance headlamps with their iconic “eyebrow” and distinctive illumination both during the daytime and at night.





Lower, longer, wider: From the GLE to the GLE Coupé

The new GLE Coupé is 81 mm longer than the GLE. A stylistic stimulus which the Mercedes-Benz designers promptly translated into an irresistibly athletic coupé line. The additional width of 68 mm also facilitates a sportier track width. The car stands firm and dominant on the road. The characteristic sports car proportions arise in conjunction with the height reduced by 28 mm and the gently sloping hardtop. The long line when viewed from the side is the finest symbol of this new, unimagined dynamism.

What makes a car a Mercedes?

Deep-rooted traditions: in our case, it is innovative traditions that run deep. We have continually gone down previously uncharted avenues. Milestone by milestone. These ventures spawned the first vehicle with a crumple zone, the first ABS, the first diesel passenger car. The first car. But rather than wallowing in the past, let us look to the future.

Mercedes-Benz Intelligent Drive – on the road to accident-free driving. We develop intelligent assistance systems which actively support the driver and noticeably relieve their workload. They monitor and analyse the vehicle's surroundings and handling characteristics – and warn the driver if they identify any critical situations. When necessary, some of the systems are able to intervene to take corrective action. Potential dangers are identified earlier than ever – and ever more frequently avoided as a result.

4MATIC – driven by new challenges, the vision of optimum traction led the Mercedes-Benz engineers to the

International Motor Show in Frankfurt. That is where, in 1985, they unveiled 4MATIC, an innovative traction system working with state-of-the-art microelectronics and hydraulics. Just two years later it entered series production in the E-Class. It has continued its triumphal advance ever since in virtually all model series. And on every terrain. 75 models are now out on the road with 4MATIC and it is tailor-made for each class. Comfortable and efficiently configured for the compact class, right through to extremely sporty for the Mercedes-AMG performance models. For more safety and an intensive driving experience in every single moment.

As you can see, we have major goals in our sights. And what could be better than seeing these aims achieved whilst on a long drive in a Mercedes?



AMG-enhanced biturbo V6: Thoroughbred power, from the place where horses are raised.

A new pedigree in power comes from exclusive AMG enhancements including a modified boost pressure developed by AMG engineers. With 270 kW (367 hp) and 520 Nm, the V6 engine sets new standards in its segment – which is evident in the convincing performance: a sprint time from 0 to 100 km/h of 5.7 seconds underscores the sporty temperament of the Mercedes-Benz GLE 450 AMG Coupé. The maximum possible 520 Nm are available between 1800–4000 rpm. This facilitates astonishingly low engine speeds. A technological package, comprising power, refinement and efficiency, which can hardly be overtaken. An exclusive red engine cover insert heightens power, torque and the emotions they inspire in true enthusiasts.



*Please read the disclaimer.

Mercedes-Benz GLE 450 AMG Coupé with an output of 270 kW (367 hp) and 520 Nm of torque

9G-TRONIC. The driving force masquerading as a transmission.

With nine forward gears, the **9G-TRONIC** automatic transmission enables efficiency, comfort and dynamism of an entirely new dimension. Its high efficiency helps to reduce fuel consumption. The larger ratio range allows a reduction in engine speed. Performance remains excellent while ride comfort is enhanced and noise levels are cut. The reduced intervals between the gears lead to faster gear changes and enhanced spontaneity and agility. As the 9G-TRONIC is able to skip individual gears, multiple downshifts are possible for fast and powerful sprints.

Powertrain systems

The standard-fit **ECO start/stop** function shuts off the engine temporarily at a red light or in a traffic jam to further lower fuel consumption.

Cruise control with **SPEEDTRONIC** variable speed limiter enhances comfort and safety.

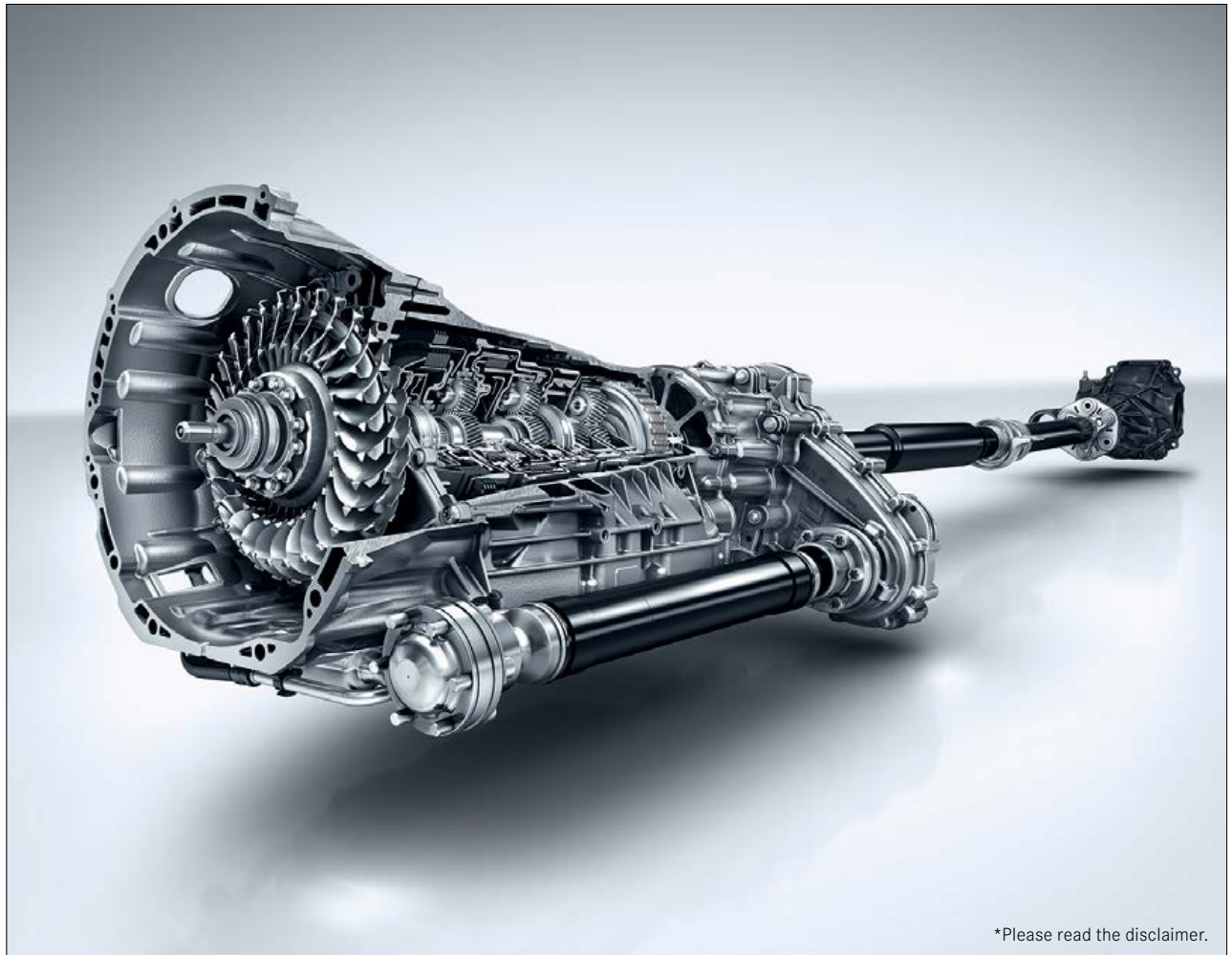

*Please read the disclaimer.

Strength of character: the DYNAMIC SELECT transmission modes.

The DYNAMIC SELECT variable dynamic control system assigns fundamentally different characteristics to the five transmission modes of Individual, Comfort, Slippery, Sport and Sport Plus, which the driver is able to select using a rotary control on the center console. The system networks all the control systems, generating different driving experience parameters. The names speak for themselves: Sport and Sport Plus turn the Mercedes-Benz GLE 450 AMG Coupé into a sporty, dynamic vehicle with pronounced longitudinal and lateral dynamics. Comfort is the opposite end of the spectrum. Slippery optimises the handling on surfaces with low friction co-efficients. In addition, individual mode enables the driver to program and store personal preferences in the individual control strategies.

In the Mercedes-Benz GLE 450 AMG Coupé, DYNAMIC SELECT not only modulates the “hard skills” such as the chassis and suspension, steering or powertrain. It is also possible to experience the selected mode more intensively on an emotional level because various “soft skills” such as the engine sound, instruments or dynamic control of the driving lights also vary. To this end, the nature of the various displays on the COMAND screen and in the cockpit changes according to the selected transmission mode. At the same time, the active light function of the all-LED headlamps responds more spontaneously, the light functions of the Highbeam Assist switch faster and the engine produces the whole range of sounds from sporty and dominant to poised and reticent.



*Please read the disclaimer.



*Please read the disclaimer.

Emotional intelligence: The AIRMATIC package.

With the Adaptive Damping System ADS PLUS, the air suspension AIRMATIC – available as standard – reduces road roar and tyre vibration characteristics, whilst also ensuring excellent driving dynamics. The damping at each wheel is adapted to the driving situation and road surface condition. Pitching and rolling can be effectively reduced, for example when cornering or braking. The driver can decide on a comfortable or more sporty

configuration for the AIRMATIC air suspension. The self-levelling system ensures that the level of the car remains constant, irrespective of the load and driving condition. At high speeds and in the “Sport” transmission mode the car is lowered by up to 15 mm, and by as much as 25 mm in the “Sport Plus” transmission mode helping to reduce wind resistance and improve handling stability.



*Please read the disclaimer.

AMG-specific 4MATIC all-wheel drive

Excellent driving characteristics on any surface – ensured by 4MATIC permanent all-wheel drive in conjunction with ABS, ESP® and the 4ETS Electronic Traction System. On or off-road, in wet weather, slippery terrain: traction, driving dynamics and driving stability are improved. The main component here is an AMG-specific single-stage transfer case with an open planetary center differential, which balances the difference in speed between the axles. The brake force distribution of 40:60 between the front and rear axles guarantees enhanced driving dynamics and higher traction while accelerating.



*Please read the disclaimer.

Technical Highlights

Sports Direct-Steer System

The combination of the AMG specific Sports Direct-Steer system, compact performance steering wheel, elastokinematics on the front axle and more robustly designed rear-axle stabilizer bar, leads to an outstanding handling in all operating conditions. The variable steering ratio makes for significantly improved agility, while high-speed driving safety is maintained. The variable power assistance is dependent on the vehicle speed and the DYNAMIC SELECT program and adapts perfectly to the driving situation.



Braking System with Optimised Brake Cooling

The Mercedes-Benz GLE 450 AMG Coupé comes with a large-sized braking system with internally ventilated brake discs, measuring 375 mm in diameter and with two-piston floating callipers on the front axle, and 345 mm in diameter and with single-piston floating calliper on the rear. Thanks to special air-ducting which guides the air flow towards the inside of the brake discs, the cooling of the brakes is further optimised.

*Please read the disclaimer.

Exhaust System

The 2-pipe exhaust system with integrated chrome-plated tailpipe trim and centerpiece for a four-pipe look sets a sporty tone at the rear. In combination with a special, sporty engine sound including backfire sound once again the vehicle's power and performance is clearly emphasized.



Downhill Speed Regulation (DSR) – the safe and relaxed way to drive downhill

This system allows a speed of between 2 and 18 km/h to be set when driving down steep hills. As far as the laws of physics allow, this speed is then maintained with the help of the engine and transmission controls as well as braking intervention. DSR thus makes driving downhill easy and increases active safety in off-road situations. The driver can switch DSR on via a button in the centre console and then uses the cruise control lever to set the desired downhill speed.



ECO Start/Stop System

A fuel-saving ECO Start/Stop system automatically shuts off the engine at stoplights and other idle situations. As soon as the driver lifts off the brake, the engine instantly restarts, for immediate acceleration response. This system can also be shut off by the driver at any time.



*Please read the disclaimer.



*Please read the disclaimer.

Exterior – Make a grand entrance.

The GLE Coupé is a successful combination of SUV and coupé. The design exudes sportiness and superiority. The prominent front with radiator trim typical of a coupé differentiates it from its off-roader sibling - the GLE - at first sight. In design terms, the coupé-typical lines of the side view underscore the sportiness and on-road character. The rear end design is eye-catching, thanks to the low roof and impressive vehicle width. The sportily striking AMG elements with exclusive highlights in black and silver chrome, make the enhanced performance discernible at the very first glance.

HIGHLIGHTS AT A GLANCE

Contoured powerdomes on the bonnet

Vertical radiator trim with centrally positioned Mercedes star, typical of a coupé with single louvre

LED Intelligent Light System

Daytime running lamps featuring LED fibre optics integrated into the upper part of the headlamps

Tail lights with LED technology

AMG bodystyling with specific AMG Sport model front and rear apron

Exterior mirror housings, shoulderline trim strips and window strips in black

AMG spoiler lip, painted in vehicle colour

Perforated brake discs at the front, brake calipers with painted brake caliper covers and “Mercedes-Benz” lettering

“AMG” badge on the front wings

Two chrome-plated AMG tailpipe trim elements with centrepiece for a four-pipe look

Highlights in silver chrome in the AMG rear apron

Chrome panels in the tailgate above the tail lights

Cladding on the wheel arches and above the side skirts

Aluminium-look running boards with rubber studs

53.3 cm (21-inch) AMG 5-twin-spoke light-alloy wheels, painted in black and in a high-shine finish



*Please read the disclaimer.

LED Intelligent Light System – more visibility in every situation.

For the best possible visibility on country roads and motorways, when cornering and on bends, the low beam mode of the LED Intelligent Light System automatically adapts to the weather, lighting and driving conditions. The LED Intelligent Light System thus makes a key contribution to safe driving. LED technology impresses with its very low energy consumption, long operating life and pleasant white light that comes close to the spectrum of natural daylight.



Features of the LED Intelligent Light System:

Adapts headlamps automatically to typical driving and weather situations

Country & motorway mode replace dipped beam – Active above 90 km/h

Active light function swings the headlamps into bends by up to 15°

Corner light function improves illumination on corners & tight bends

The enhanced fog lamp function illuminates the outer half of the carriageway more effectively while reducing the glare due to light reflected by the fog

*Please read the disclaimer.



Mirror Package – more comfort, improved visibility.

The exterior mirrors are electrically folding in order to protect the housing. For enhanced perception, the exterior mirror on the driver's side and the rear-view mirror are automatically and continuously self-dimming. A highlight is the surround lighting with projection of the brand logo.





*Please read the disclaimer.

Interior. Excitingly luxurious.

The cockpit of a GLE Coupé makes it easy to oversee its exceptional roster of capabilities. Its engineers overlooked nothing in setting it up for you. For your every sense, there's a sense of invigoration, from multi-color LED ambient lighting and front cup holders that can help keep your beverages warmer or cooler, to a wide array of available features from the thoughtful to the indulgent. The interior of the Mercedes-Benz GLE 450 AMG Coupé is an impressive sight with AMG sports seats and the black nappa leather AMG sports steering wheel in 3-spoke design as well as the trim elements in light longitudinal-grain aluminum. A high standard of quality and design is also manifested in the AMG floor mats in high-quality velour with imitation nubuck edging and embroidered "AMG" lettering. The brushed stainless steel sports pedals bring functionality and visual appeal from the world of motorsport. And a Panoramic roof can open up the sky to everyone onboard.

HIGHLIGHTS AT A GLANCE

Sports seat for driver and front passenger with upholstery in ARTICO man-made leather

Upper section of dashboard in ARTICO man-made leather

3-spoke multifunction sports steering wheel in black nappa leather, with flattened bottom section

Instrument cluster with dial in chequered-flag look

Brushed stainless steel sports pedals with rubber studs

AMG floor mats with "AMG" lettering

DYNAMIC SELECT with five transmission modes

4-way lumbar support for driver and front passenger

Media Interface cable kit

DVD changer with six compartments

Ambient lighting

Emergency spare wheel is housed in the boot recess

THERMOTRONIC - automatic climate control system with 3 climate zones

Front and rear ashtray inserts in the stowage compartments as well as cigarette lighter in the front

Temperature-controlled cup holder

Panoramic sliding sunroof

*Please read the disclaimer.

Standard Equipment.

Sports Seats

The new Mercedes-Benz GLE 450 AMG Coupé is fitted as standard with electrically adjustable sports seats for the driver and front passenger. With their high side cushions, the sports seats provide the driver and front passenger with plenty of support, even during higher lateral acceleration, and at the same time offer maximum seating comfort. In addition they are fully power-adjustable. The upholstery in ARTICO man-made leather with AMG Line seat upholstery layout provides the driver and passengers with a sporty look and feel.



Memory Package

Perfect settings every time. The Memory package is especially convenient if the vehicle is used by more than one person. Up to three different positions for the electrically adjustable front seats, steering column and exterior mirrors can be stored and retrieved at the touch of a button. Operation is intuitive using ergonomic switches in the door control panels. For a better view when reversing into parking spaces, the exterior mirror on the front passenger side can be automatically lowered when reverse gear is engaged.



*Please read the disclaimer.

Standard Equipment.

Panoramic Sliding Sunroof

With its large glazed area, the panoramic sliding sunroof ensures a particularly bright and welcoming ambience in the interior. The outer layer of the full-glass roof with the sliding sunroof on the exterior comprises two separate glazed elements made of safety glass. The movable glass section can be electrically tilted, raised and slid lengthwise towards the rear. The wind deflector is automatically raised when the movable glass cover slides towards the rear.



Ambient Lighting

Climb in and feel at home – with its pleasant, indirect light, the ambient lighting creates a unique sense of well-being throughout the entire interior. 3 different colours are available to achieve the desired lighting mood. The brightness can be dimmed in 5 stages.



*Please read the disclaimer.

Standard Equipment.

Temperature-controlled Cup Holder

A cool or warm drink always within reach – a convenience enjoyed by driver and front passenger thanks to the temperature-controlled cup holder. Holds bottles, cans and mugs securely in place in the centre console. A temperature of between 8° and 55° C can be maintained, according to what is required.



THERMOTRONIC Automatic Climate Control

The automatic climate control system with 3 climate zones and 3 climate modes provides an individual feel-good climate on board. The temperature and air distribution can be regulated separately for driver and front/rear passengers. Sensors are used to ensure that the desired climate is kept constant in each zone.



*Please read the disclaimer.

Standard Equipment.

Easy-Pack Tailgate

The EASY-PACK tailgate can be opened and closed at the touch of a button for more convenient loading and unloading of the boot.



Instrument Cluster

The instrument cluster, with its two large round dials and a central colour multifunction display with an 11.4 cm screen diagonal, presents all important items of information in the driver's field of vision. The ISO display encourages a fuel-efficient driving style.



*Please read the disclaimer.

Infotainment in the new GLE Coupé.

Navigation, telephone, audio, video, internet – with the **COMAND Online** control and display system the driver is able to keep these and many other functions in view and under control. The data are shown in high resolution on the centrally positioned, particularly fine glass display with a 20.3 cm screen diagonal. The touchpad facilitates intuitive operation using finger gestures, and the user can enter letters, special characters and numbers in their own handwriting.



*Please read the disclaimer.

Garmin® MAP PILOT

User-friendly navigation and excellent route guidance – the Garmin® MAP PILOT navigation system brings all the benefits to the audio system. The maps have a Garmin look and feel and appear in high resolution and in colour on the multimedia system's large display, with additional navigation information in the instrument cluster.



*Please read the disclaimer.

The reassuring feeling of driving a Mercedes-Benz.

We are the first automotive manufacturer worldwide to have developed an integral safety concept, aimed at avoiding accidents, ensuring ideal responses to dangers and lessening the consequences of accidents. For the occupants of a Mercedes as well as for other road users.

Adaptive Highbeam Assist Plus

The Adaptive Highbeam Assist Plus allows the main-beam headlamps to be kept on permanently since oncoming traffic or vehicles in front are masked out in the beams' cone of light.

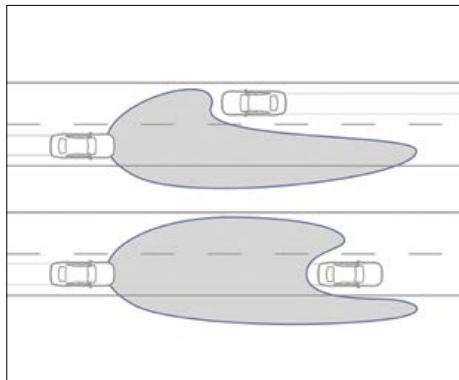

ATTENTION ASSIST

The ATTENTION ASSIST can detect typical signs of drowsiness in the steering behaviour and warn the driver.



Crosswind Assist

An additional function of the ESP® is the Crosswind Assist with automatic lane-correcting brake actuations. A permanent all-wheel drive, 4MATIC, ensures stability, dynamism and safety, even in difficult weather or road conditions. Brake force distribution is via a single-stage transfer case.

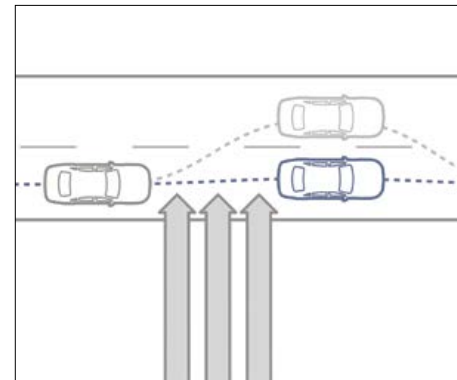

Electronic Traction System

The electronic traction system 4ETS can prevent the driven wheels from spinning on one side when moving off and accelerating by means of brake actuation, as well as preventing both driven wheels from spinning momentarily when cornering within certain speed ranges.

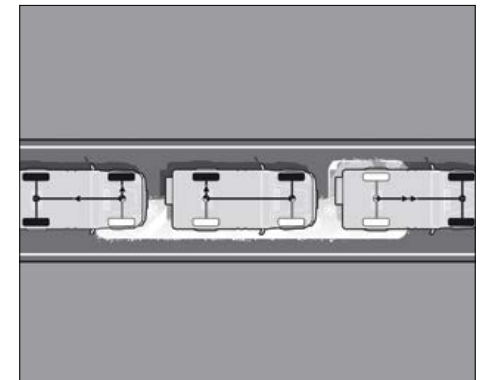

*Please read the disclaimer.

In the event of danger

The occupant protection system PRE-SAFE® is able to identify critical driving situations in advance and to initiate precautionary measures to protect the car's occupants if an accident appears imminent. Such measures include reversible belt tensing or automatic closing of open side windows, for example.

In an accident

Six airbags help prevent injuries or reduce the risk of injury in the event of a collision. The two adaptive front airbags deploy in either one or two stages, depending on the severity of the impact. Furthermore, the Mercedes-Benz GLE 450 AMG Coupé has sidebags for driver and front passenger and two large window-bags extending over both rows of seats.

After an accident

Every Mercedes-Benz is fully trained in first aid. If the worst comes to the worst, the engine can be switched off automatically, the hazard warning lamps and emergency interior lighting can be activated, and the central locking can be unlocked. Also as a part of the Memory Package, the EASY-EXIT feature for driver automatically raises the electrically adjustable steering column to facilitate rescue of occupants by others or self-rescue.

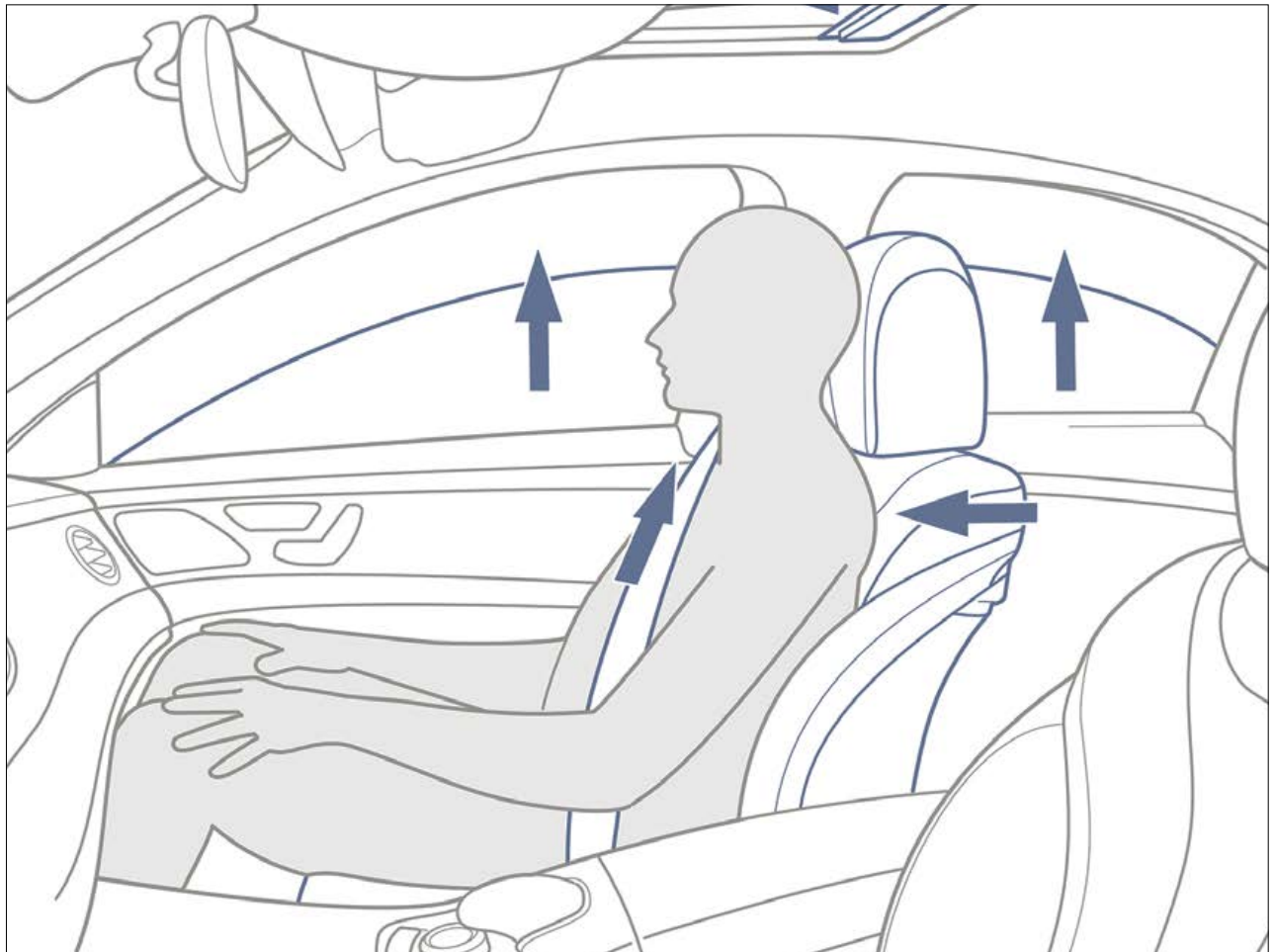

PRE-SAFE®

*Please read the disclaimer.

That certain something extra. The genuine accessories.

Individualise the new Mercedes-Benz GLE 450 AMG Coupé with the range of genuine accessories. These cover every conceivable need for more enjoyable, more pleasant and more practical motoring.

Travel and Style equipment: The head restraint elements are simple to fit and remove. The modular system centres around a base support which can be combined with various products – a coat hanger, a universal hook or a folding table.



Genuine Accessories

Aerodynamic roof box designed to fit the GLE Coupé, made of extremely durable material. Fast, optimised mounting on the separately available basic carrier bars. Convenient loading and unloading, as it can be opened and closed on both sides.

An elegant **DVD system** allows the rear passengers to watch DVDs, look at their favorite pictures and even play video games on two superb 17.8 cm color screens and thus keeping them entertained during your journey – and outside the vehicle, as the monitors can be removed from the mount with a click and used anywhere with the aid of the 230V/12V mains adapter additionally provided.

The illuminated Mercedes Star for the radiator grille is a particularly eye-catching feature. Thanks to fibre-optic cable and LED technology the central Star is illuminated when unlocking the car via remote control and when opening doors or the tailgate (functionality only when the engine is switched off). In all likelihood available from 4th quarter of 2015.



*Please read the disclaimer.

Genuine Accessories

Mercedes-Benz Child Safety

Mercedes-Benz child seats offer optimum protection in the event of an accident. Child seats are tested and inspected to exacting Mercedes-Benz specifications.

“BABY-SAFE plus II” child seat - Deep, moulded seat design offers extra side-impact protection for optimum safety. Special padding, designed to protect particularly vulnerable body areas of children up to around 15 months (up to 13 kg).

“DUO plus” child seat - Optimum safety for children between the ages of around 8 months and 4 years (9 to 18 kg). Fitted as standard with top tether, an additional belt for securing the head section, a height-adjustable shoulder belt, ventilation channels and ISOFIX attachment.

“KIDFIX” child seat - Booster seat for optimum side-impact protection, with height adjustable backrest. The “KIDFIX” seat is secured using the 3-point seat belt and ISOFIT attachment points. For children between the ages of around 3.5 and 12 (15 to 36 kg).



“BABY-SAFE plus II” child seat



“DUO plus” child seat



“KIDFIX” child seat

*Please read the disclaimer.

Genuine Accessories

Alloys

Wheels are indispensable on technical grounds, of course. But on an emotional level, too, perfect wheels are an absolutely crucial ingredient of many people's dream car. With this in mind, we have put together a particularly large and diverse selection for you.



5-twin-spoke light-alloy wheels, painted himalayas grey with a high-sheen finish, with 275/45 R21 front and 315/40 R21 rear tyre



5-twin-spoke light-alloy wheels, painted vanadium silver with a high-sheen finish, with 275/50 R20



5-spoke light-alloy wheels, painted himalayas grey with a high-sheen finish, with 275/45 R21 front and 315/40 R21 rear tyres

*Please read the disclaimer.

Upholstery, Trim and Alloy

Upholstery

Black

Ginger Beige / Black

Crystal Grey / Black

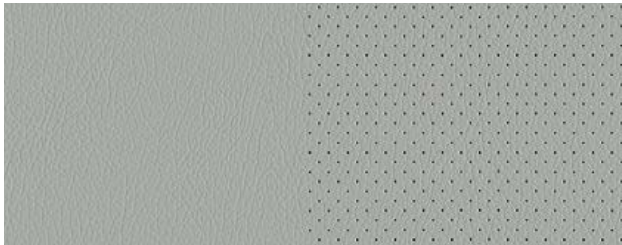
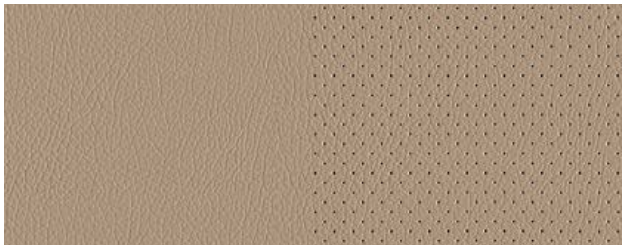
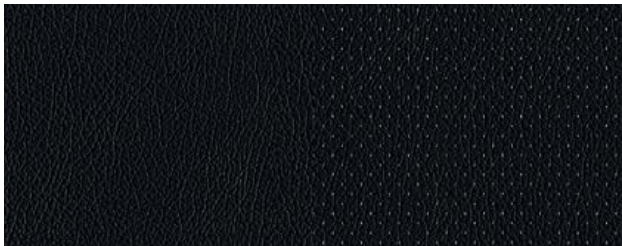

Trim

Light Longitudinal-grain Aluminium



Alloy

53.3 cm (21-inch) AMG 5-twin-spoke light-alloy wheel



*Please read the disclaimer.

Paintwork

Metallic Paints

Obsidian Black

Tenorite Grey

Cavansite Blue

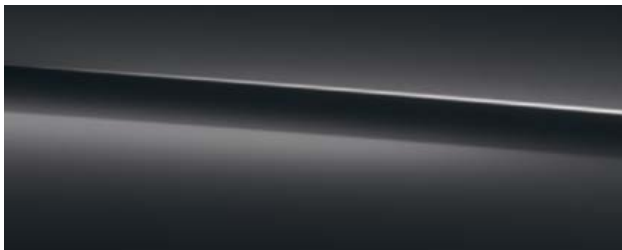

Non-Metallic Paint

Polar White



designo Paint

designo Hyacinth Red Metallic

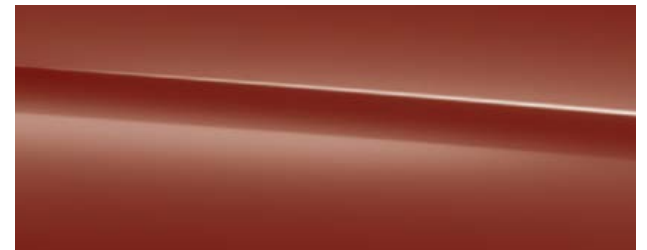

*Please read the disclaimer.

Technical Data.

	Mercedes-Benz GLE 450 AMG Coupé
Arrangement / No. of cylinders	V6
Total displacement in cc	2996
Rated output in kW (hp) at rpm	270 (367)/5500-6000
Rated torque in Nm at rpm	520/2000 - 4200
Transmission	9G-TRONIC
Acceleration from 0 to 100 km/h in s	5.7
Top speed, approx. in km/h	250
Tyre size - front axle, rear axle	275/45 R21, 315/40 R21
Fuel	Petrol
Tank capacity, of which reserve, approx. in litres	93/12.0
Boot capacity in in litres	650-1720
Turning circle diameter in m	11.80
Kerb weight in kg	2280
Perm. GVW in kg	2880

*Please read the disclaimer.

Dimensions

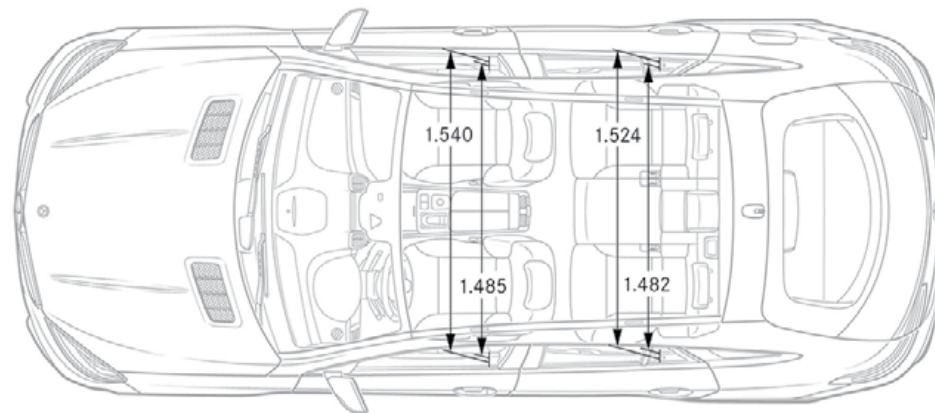
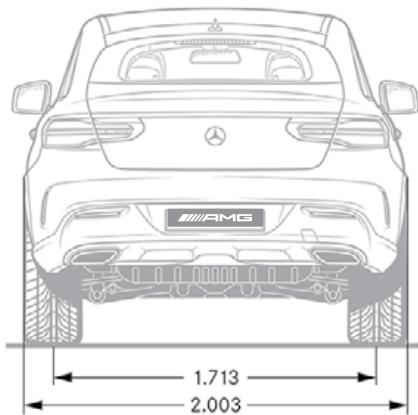
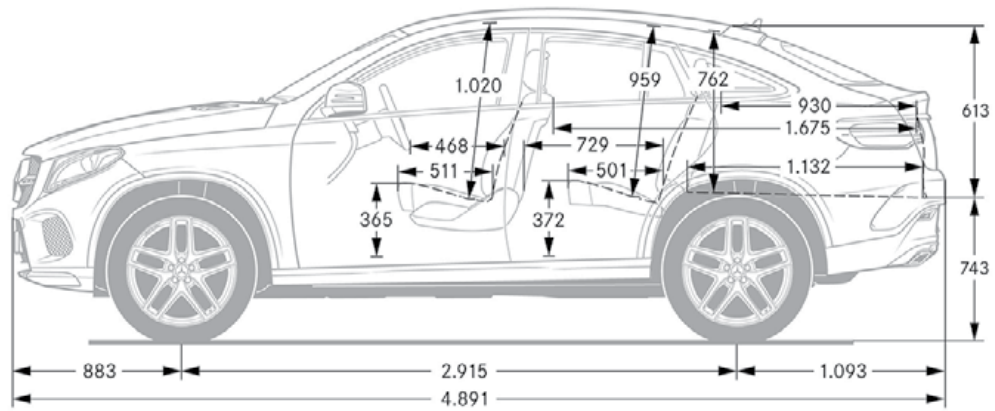
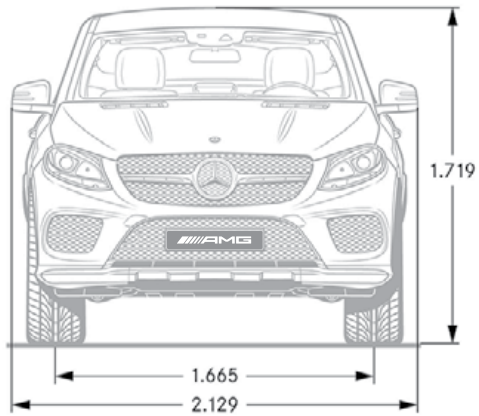

All measurements in millimetres. The dimensions shown are mean values and apply to standard-specification, unladen vehicles.

*Please read the disclaimer.

Service

The luxurious experience of driving a Mercedes-Benz is converted into a fulfilling ownership experience with a range of exclusive services and special programmes.

Cost of Ownership

There has been a paradigm shift in the buying preferences of Indian consumers over the years, even for the luxury products. The purchase decision not only dwells around cost of acquisition but also the total 'Cost of Ownership' (COO). Amongst the key components of COO in cars are the routine service jobs and the unplanned repair

expenses post the warranty period. We are now offering highly-affordable Service Packages and Extended Warranty Programmes which are the most competitive packages in its class. All in all, we provide you with a controlled Cost of Ownership while you benefit from the legendary Mercedes-Benz service quality.

Experience complete peace of mind when you drive the Star

STAR CARE programme offers peace of mind for you during the warranty period and beyond. While our cars are covered for warrantable repairs of up to 3 years without any mileage limitations as standard, you can also buy STAR CARE Plus programme, offering 4th year extended warranty. Additionally, the programme enhances the resale value of your car.



Extended Warranty that guarantees complete peace of mind

*Please read the disclaimer.

STAR EASE service package gives you the freedom to relax behind the wheel and puts your mind at ease with its range of unique benefits such as defined cost of maintenance and priority handling. STAR EASE comprehensive package covers essential jobs related to periodic service (viz. oil, filters, consumables etc.) along with coverage for brake pads, brake discs, wiper blades, wheel alignment and balancing for a contracted period. For further details on products and pricing, please contact your nearest Mercedes-Benz dealer.

On-Road Assistance Programme

As part of our ongoing commitment to you, Mercedes-Benz On-Road Assistance is designed to enhance your overall Mercedes-Benz ownership experience by providing you with 24-hour On-Road Assistance. Mercedes-Benz is the only luxury car manufacturer to offer round-the-clock On-Road Assistance for 3 years from purchase of the vehicle as a standard offering. Peace of mind motoring – guaranteed.



The maintenance of your Star is just as peaceful as driving it



Always at your service

Conditions apply.

*Please read the disclaimer.

India's Largest Luxury Car Network

It takes a keen sense of responsibility to provide the Best. Our large network is spread across the country in 40 cities with 81 outlets and is still growing. With world-class showrooms, state-of-the-art workshops and highly skilled personnel, experience the best wherever you go.



DEALER CONTACT:

NORTH & EAST:

BHUBANESWAR:
Tristar Motors: 0-7852944100

CHANDIGARH:
Joshi Autozone: 0172-5050500
Panjab Motors: 0172-4290000

DEHRADUN:
Berkeley Motors: 0135-3054000

DELHI:
Patel Auto Services, Rajendra Place:
011-47626262/0-9810081048

T & T Motors, Mohan Co-operative,
Mathura Road: 011-66574300/330
Rajouri Garden: 011-66574400/430

GHAZIABAD:
Silver Arrows: 0-9718200500

GURGAON:
T & T Motors: 0124-4263060/62

JAIPUR:
T & T Motors: 0141-4300000/05

JAMSHEDPUR:
Tristar Motors: 0-7763815720/
0657-6601601/02

JALANDHAR:
Joshi Autozone: 0181-5004444

KANPUR:
Smart Hoops: 0-8795663300

KARNAL:
Berkeley Motors: 0184-3300000

KOLKATA:
Benchmark Interkrafts: 1800 3000 3310

LUCKNOW:
Smart Hoops: 0522-6004008/9

LUDHIANA:
Joshi Autozone: 0161-5055000

MOHALI:
Panjab Motors: 0172-4290000

NOIDA:
Silver Arrows: 0-9999200500

WEST:

AHMEDABAD:
Benchmark Cars: 0-9377662000

AURANGABAD:
B. U. Bhandari: 0-8605121333/
0240-6452601/02

BHOPAL:
Benchmark Cars: 0-9098233233

GOA:
Counto Motors: 0832-2415122

INDORE:
Benchmark Cars: 1800-3000-8844

KOLHAPUR:
B. U. Bhandari: 0231-2661422/
0-8380093555

MUMBAI:
Auto Hangar, Prabhadevi: 022-67434362/63
Auto Hangar, Andheri: 022-67106660/61

Metro Motors, Auto Hangar division
Hughes Road: 022-66123500/11

Shaman Wheels, Off BKC: 022-24228787

NAVI MUMBAI:
Shaman Wheels: 022-24228787

NAGPUR:
Auto Hangar: 0-9223540191/
07104-238180/1/2/3

NASHIK:
Indisch Motoren: 0253-6645555

PUNE:
B. U. Bhandari, Baner: 020-67212129
Pune City Showroom: 020-67212131

RAJKOT:
Benchmark Cars: 0-9377750050

RAIPUR:
Auto Hangar: 0771-6537801/0-8518887155

SURAT:
Benchmark Cars: 0-9377660066

VADODARA:
Benchmark Cars: 0-9377390001

SOUTH:

BENGALURU:
Sundaram Motors: 080-22070720/21

Akshaya Motors, Mysore Road:
080-22966300, 0-9066030989

Akshaya Motors, Koramangala:
080-22966296, 0-9019326026

CALICUT:
Bridgeway Motors: 0495-30 55555

CHENNAI:
Trans Car: 044-40200300

Titanium Motors: 044-66498080/8181/8282

COIMBATORE:
Sundaram Motors: 0422-2452020

COCHIN:
Rajasree Motors:
0484-2706332/2706432/2706134
2607027/37/47

HYDERABAD:
Mahavir Motors: 040-43403004

MADURAI:
Sundaram Motors: 0452-2320433/
0-9500966946

MANGALORE:
Sundaram Motors: 0824-2214833/2215833/
0-9008442155

TRIVANDRUM:
Rajasree Motors: 0471-2380377/
0-9846547551

VIJAYAWADA:
Mahavir Motors: 0866-2082559/
0-9885303004

MERCEDES-BENZ CERTIFIED:

AHMEDABAD:
Benchmark Cars: 0-9016665000

BENGALURU:
Akshaya Motors: 0-9019944044
Sundaram Motors: 080-22070746/
0-9880662051

CHANDIGARH:
Joshi Autozone: 0-9878941930/ 0172-
5050500/510

CHENNAI:
Transcar: 0-9841049994

DELHI:
T&T Motors, Mathura Road: 0-9711774424
T&T Motors, West Delhi: 0-9711112243

GHAZIABAD:
Silver Arrows: 0-9718200500

HYDERABAD:
Adishwar: 0-7799633004

KOCHI:
Rajasree Motors: 0-9846547311

MOHALI:
Panjab Motors: 0172-4290000

MUMBAI:
Autohangar India: 0-9223546204,
0-9223547099

Shaman Wheels: 0-9619023450/ 022-
69543333

PUNE:
B U Bhandari: 020-67212172/0-8605118555

AMG PERFORMANCE CENTERS:

BENGALURU:
Sundaram Motors: 080-22070720/21

DELHI:
T&T Motors: 011-66574309

HYDERABAD:
Mahavir Motors: 0-9885033004/
0-9885653004

MUMBAI:
Auto Hangar: 022-67434360/61/65

PUNE:
B.U. Bhandari: 020-67212131/0-8554055555

Our national toll-free no.:

1800 102 9222

One Call. All Answers.

For a complete list of Mercedes-Benz outlets, please explore the dealer locator tab on www.mercedes-benz.co.in

Mercedes-Benz India Private Limited: E-3, MIDC Chakan - Phase III, Chakan Industrial Area, Kuruli & Nighoje, Tal: Khed, Pune - 410 501 (India)
Toll free No.: 1800 102 9222. e-mail: customerconnect@daimler.com, **website: www.mercedes-benz.co.in**

Please note: This brochure is intended for general information, description and illustration of the Product including optional functions and equipment and may not be specific to a Product since specification of a product may change from time to time. Optional features, functions and equipment etc. may not be present in the Standard or Variant Product or Special Edition Product. Further, Standard specifications of a product may also vary from time to time. Colours may differ from those shown in pictures in the brochure, owing to printing. Mercedes-Benz India reserves the right to make changes, at any point of time, without prior notice, in design, colours, materials, components, equipment, specifications, features, functions, make and models etc. The information given in this brochure shall be regarded as accurate at the time of going to print and may vary thereafter due to any developments or any other reason. Interested parties should confirm with the Authorised Dealer about the correct specification of the product they desire to purchase. For the latest authentic information and updates, kindly contact your nearest Authorised Dealer.

All title, ownership rights and intellectual property rights in and relating to this brochure / magazine or publication material or any copies thereof including but not limited to copyright, logos, names, trademarks, service marks, design, text, images, links, concepts and themes are owned by Daimler AG and/or its subsidiaries collectively or used under authorised license by the Daimler AG. Any reproduction, transmission, publication, performance, broadcast, alteration, license, creation of derivative works or other use in whole or in part in any manner without the prior written consent of the Daimler AG is strictly prohibited.

Month of going to press: January, 2016. Mercedes-Benz cars: Mercedes-Benz GLE 450 AMG Coupé meets Bharat Stage IV equivalent emission norms.
CIN - U34102PN1994PTC083160